



# Symmetrical Services Over HFC Networks

White Paper

January 2003



## Symmetrical Services Over HFC Networks

### Introduction

In today's tough business climate, MSOs are seeking highly cost-effective solutions that allow them to squeeze every possible bit and cycle out of their existing networks - to maximize revenues and substantially raise ARPU.

Provision of legacy video broadcasting service alone is no longer sufficient for MSOs. Thus, there are a number of new revenue sources to which MSOs are turning:

- \* attracting new and lucrative SMB (Small/Medium Business) data customers.
- \* providing existing residential users with the "triple play" of voice, data, and video services
- \* increasing broadcast quality through high-definition TV (HDTV)

All of these sources require more bandwidth, both downstream and upstream, than today's installed HFC networks can provide.

Xtend Networks enables MSOs to attain new revenue streams while leveraging existing coax networks - relieving the bandwidth bottleneck by extending bandwidth up to 3GHz. Xtend allows MSOs to:

- \* Deliver voice, data, and video services to customers, while keeping equipment and construction costs low, preserving investment in HFC infrastructure, and attaining rapid ROI.
- \* Quickly deploy and implement these solutions in metro service areas.
- \* Offer clients new value-added products, features, and services not currently available

### Business Bandwidth Requirements

Market studies expect that bandwidth consumption will grow over the next few years. Applications such as VoD (Video on Demand), video sessions, and digital cinema for residential subscribers will require more Mbps bandwidth to each home. Network collaboration, distributed databases and Internet services will require tens of Mbps for business customers.

According to the Yankee Group, "SMB (Small/Medium Business) bandwidth requirements are now far beyond dial-up, and the need for basic broadband services has been clearly established. " However, no economically viable broadband solution for MSOs has until now been available for the SMB market. Aside from the data rate, business customers also require high quality of service including:

- \* Guaranteed bandwidth (not shared with others)
- \* Symmetrical service (upstream rate ~ = downstream rate)

Xtend Networks enables MSOs to attain new revenue streams by providing broadband services to both SMBs and residential subscribers through existing coax



## Symmetrical Services Over HFC Networks

networks. Xtend's open-architecture solution is implemented without interfering with conventional CATV operation, through the addition of low cost modules to existing cable infrastructure.

### Can the HFC Network Support these Requirements?

Under most circumstances, existing HFC networks cannot support the high data rates that SMB customers and advanced residential services demand, while also providing service guarantees and required symmetry. The crucial limiting factor is the upstream capacity of the coax network. The fiberoptic portion of the network has extensive capacity and is not a bottleneck.

A typical HFC network allocates a large amount of capacity to downstream transmission (mainly TV signals), with the spectrum ranging between 50 - 750/860 MHz. With most of the spectrum dedicated to TV channels (analog, digital, VoD and maybe HDTV), only a small amount of unallocated bandwidth remains.

The upstream spectrum, too, is limited - available bandwidth is 5 - 42 MHz, out of which the lower frequencies cannot be used due to noise, leaving about 30 MHz of usable bandwidth. This bandwidth is required to service network monitoring, interactive TV (digital), VoD, cable telephony and cable modems.

With such a small spectrum range available, MSOs are simply unable to service business customer data needs, since each customer requires a large portion of the available bandwidth to ensure guaranteed service. It is clear that changes need to be made to the HFC network in order to enable business services to be successfully delivered.

### Options for Enlarging HFC Network Bandwidth

#### All Fiberoptic Network

In order to achieve necessary bandwidth levels, MSOs have the option of totally reconstructing the network, pulling fiberoptic cable from the fiber-node to the customer premises.

This option is prohibitively expensive, and rarely deployed. Cost estimates of a adding a fiberoptic link *per customer connection* are approximately \$40,000, and ROI requires considerable time.

#### Modifications to the coax portion of the HFC network

A more practical approach is modification of the subscriber coax path, increasing its capacity while maintaining existing active network elements. This approach is much less expensive, both from a capital and operational expenditure perspective, and significantly shortens MSOs time to revenue.

The Xtend Networks solution involves the addition of coax-based products, including amplifiers in parallel with the existing amplifiers, and up and down converters. Xtend's system adds 700 MHz of downstream and another 700 MHz of upstream spectrum capacity.



## Symmetrical Services Over HFC Networks

With the added capacity provided by Xtend's solution, MSOs can service business customers' data requirements, provide advanced voice, data, and video services to residential customers, allocate and dedicate (guarantee) bandwidth to each customer, and commit to the high quality of service today's subscribers demand.

Xtend's open architecture approach enables the MSO to select "best of breed" hardware and software for the provision of broadband services. The added spectrum provided by Xtend is based on the same standards as the existing network equipment, and MSOs can therefore continue to use standard equipment - client devices (cable modems, set-top boxes), and head-end devices (CMTs), or select new equipment that operates at standard cable TV bands.

## The Xtend Solution

Xtend Networks products are installed in the coax portion of the HFC network, adding capacity to the network by increasing the operating frequency to 3 GHz. This modification give MSOs an additional 3 Gbps in the downstream and additional 1 Gbps in the upstream to service business and residential customers within each node.

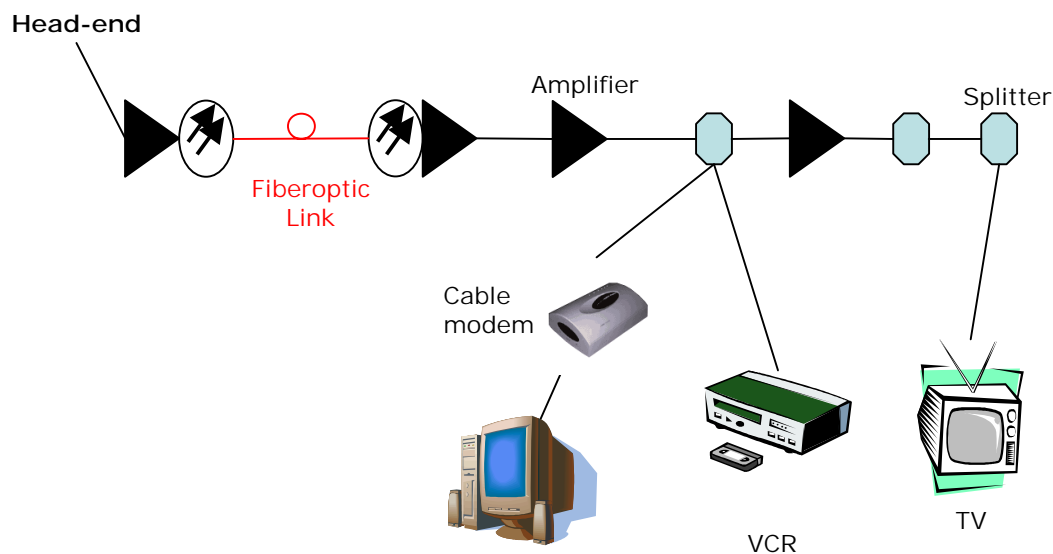

The diagram above shows the current HFC network. An HFC network starts at the head-end, where the transmission is converted to an optical signal and transported through a fiber optic link to the fiber node. The fiber node outputs the RF signal again, which is fed to the coax network.

The coax network is composed of line extender amplifiers and splitters, which take the bi-directional RF signal to the customer premises. At the customer premises the coax network feeds the cable modem, and other equipment, such as TV and VCR.



## Symmetrical Services Over HFC Networks

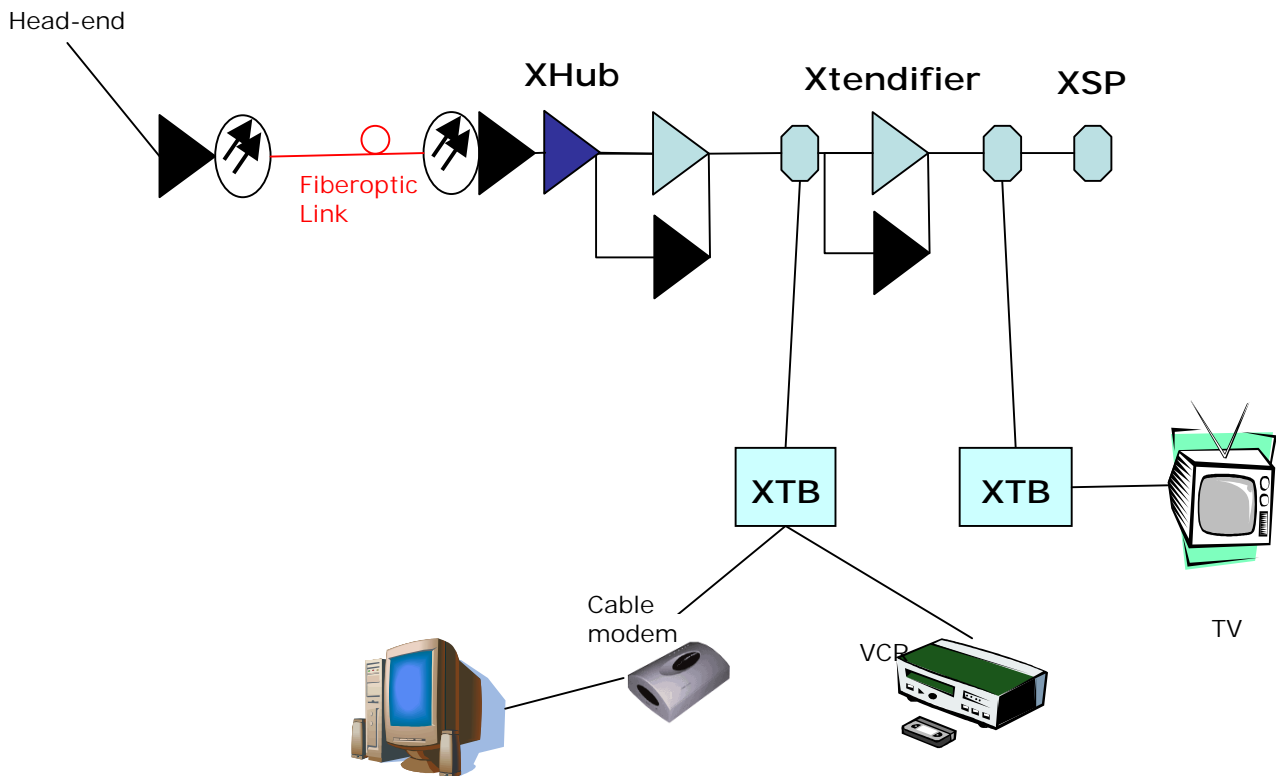

The diagram above shows the HFC network after deployment of Xtend's products. This network now has the "Xtended" capacity of additional 700 MHz downstream and another 700 MHz upstream. Using DOCSIS 1.X modulation rates, this translates into 3 Gbps additional downstream and additional 1 Gbps upstream capacity.

Xtend installs broadband amplifiers - "Xtendifiers" - in parallel to the existing amplifiers, and splitters ("XSP") and taps ("XFT") along the path to a given subscriber (subscribers not using the "xtended" spectrum do not need to receive equipment). These devices take the bi-directional RF signal to the customer premises.

Near the fiber node Xtend installs an up-converter unit, the "Xhub", which maps the added information into the new downstream band, and down-converts the added upstream information to the legacy band.

At each customer premises we install the "XTB", which performs the opposite function of the Xhub, down-converting the downstream, and up-converting the upstream.

Xtend provides standard interfaces end-to-end across the entire network - both upstream and downstream - including subscriber premises, where all existing equipment remains usable. By leaving the existing 5-860 MHz band intact, and



## Symmetrical Services Over HFC Networks

adding the "Xtended" spectrum at the 1–3 GHz band, Xtend's solution does not interfere with provision of conventional services over CATV plant.

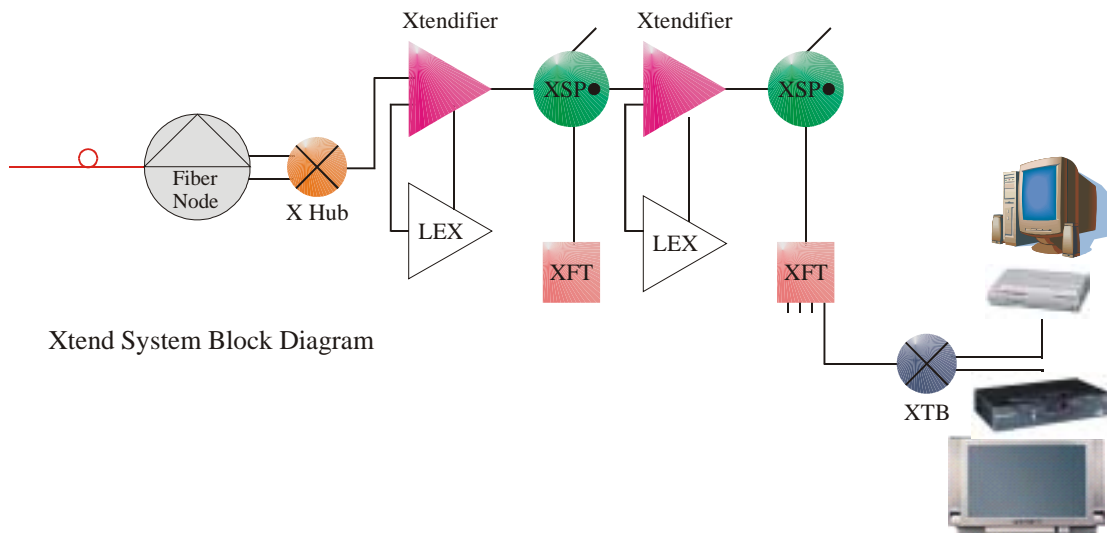

Xtend System Block Diagram

The Xtended network - from fiber node to customer premises.

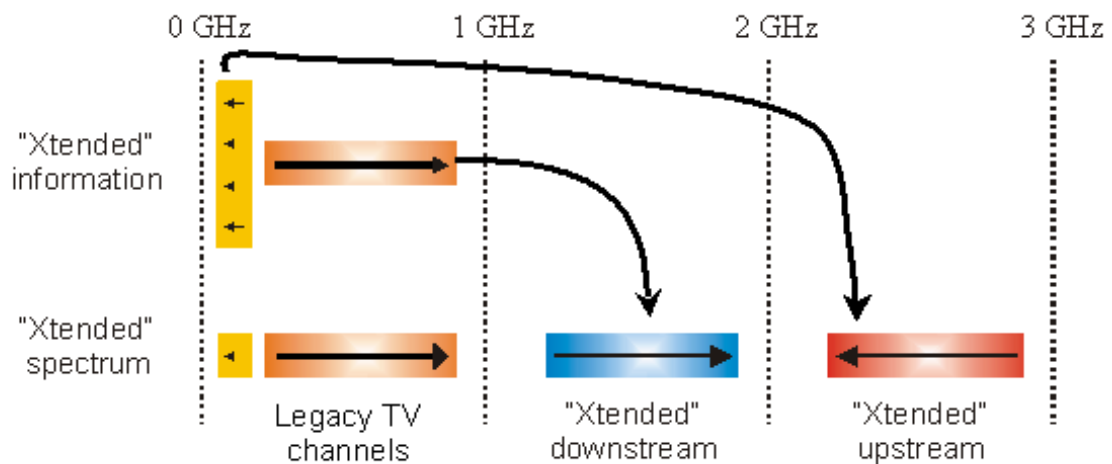

The Xtend frequency plan – how Xtend up-converts and down-converts the legacy RF spectrum to achieve capacity increase.



## Symmetrical Services Over HFC Networks

### Xtend Benefits

Through innovative RF engineering, Xtend converts the coax portion of the HFC network into a symmetrical data transport system. With these new capabilities, Xtend allows MSOs to generate additional revenues from existing residential and business clients through offering advanced, bandwidth-intensive, value-added voice, data, and video services.

Further, Xtend's solutions allow MSOs open new revenue streams through effective penetration into the lucrative SMB data services market.

Xtend lets MSOs leverage their existing HFC infrastructure, adding low-cost components that don't interfere with basic service provision. With Xtend, MSOs realize new revenues with minimal capital outlay, minimal operating costs, and rapid ROI.

Xtend Networks enables:

- \* **New Revenue Growth:** with Xtend, MSOs can provide T-1 / n \* T-1 equivalent commercial data services to SMBs.
- \* **Low Capital Expenditure:** since Xtend leverages existing coaxial plant investments, capital expenditures - construction costs, equipment costs, and support infrastructure - needed to augment the plant are minimal. Easy and rapid deployment also means fast ROI and short time to revenue.
- \* **Low Operating Expenditures:** Xtend enables the use of well-known technologies with lower operational additions to MSO, such as DOCSIS, for the delivery of high-speed symmetrical business data services. Since Xtend's solution uses standard active and passive plant elements, that MSOs are already familiar with, network support costs are nominal.

<b>Xtend Networks Ltd.</b> Gibor House, 6 Kauffman St. Tel-Aviv, Israel 68012 Tel : 972-3-5162226 Fax : 972-3-5161598 <a href="mailto:info@xtendnetworks.com">info@xtendnetworks.com</a>	<b>Xtend Networks Inc.</b> 8043 S. Saddle Brook Circle Sandy, Ut 84093, USA Tel: (801)-942-1885 Fax (509)-267-5824 <a href="mailto:blevetan@xtendnetworksna.com">blevetan@xtendnetworksna.com</a>
---------------------------------------------------------------------------------------------------------------------------------------------------------------------------------------------------------	------------------------------------------------------------------------------------------------------------------------------------------------------------------------------------------------------------------